

## Structure and Properties of Vibrating Extruded High-Density Polyethylene Sheet

Qin Xuemei , Qu Jinping (✉), Cao Xianwu

National Engineering Research Center of Novel Equipment for Polymer Processing, The Key Laboratory of Polymer Processing Engineering, Ministry of Education, South China Univ. of Tech., Guangzhou 510640, China  
e-mail: jpqu@scut.edu.cn; axue122@163.com

Received: 26 October 2005 / Revised version: 13 January 2006 / Accepted: 24 January 2006  
Published online: 7 February 2006 – © Springer-Verlag 2006

### Summary

The effect of vibration frequency and vibration amplitude on the microstructure and mechanical properties of high-density polyethylene (HDPE) sheets, obtained through electromagnetic dynamic plasticating extruder, were studied systematically. The mechanical properties, characterized by tensile and impact strengths, have been tested along the flowing and transverse directions (MD&TD). The mechanical tests show that the tensile strength and impact toughness, especially in TD, were much improved under the reciprocating axial vibration. Differential scanning calorimetry (DSC), scanning electron microcopy (SEM) and wide angle X-ray diffraction (WAXD) were executed to analyze the microstructure of the samples. The results indicate that the vibration extrudate has higher crystallinity, perfect crystallite, and strong interspherulite ties, which account for enhancement of the mechanical properties of sheets, compared to conventional static extrusion.

### Keywords:

vibration plasticating extrusion, high-density polyethylene, microstructure, mechanical properties

### Introduction

Many efforts have been made into vibration reinforced extrusion by several researchers [1-5], such as Fridman, Isayev, Ibar, Shen and Li, et al., who introduced mechanical or ultrasonic vibrations into the die during solidifying of the extrudate to acquire enhanced properties. Some investigations showed that superimposing vibrations at the exit of an extruder can improve the mechanical properties of final products and reduce the die pressure. For examples, Li, et al. [5] used a special ultrasonic vibration extrusion system to greatly improve the surface appearance of PS extrudate, and the melt flow activation energy decreased and the productivity of PS extrudate increased in the present of vibration; Ibar [3] found ultrasonic vibrations in the melt resulted in a large increase of the number of small crystals leading to better clarity and much greater strength; Shen et al [4,6] successfully utilized vibration of a

rotating annular die to control the macromolecule orientation in HDPE pipe extrusion. The most immediate effect of shear vibrating on the melt in a low frequency range (1-100Hz) is to largely decrease the melt viscosity [1,3]. This can be put into practice to control the morphology, such as diffusion, nucleation, and growth of crystals, molecular orientation and phase dispersion, which are well known to be responsible for the resultant properties of the materials [6-8].

However, most of the processing operations exert the vibration into the melt limited to the area inside the die. Thus the vibration effect is very limited because the polymer vibration just presented in a local section; on the other hand, it is difficult to extend to practical manufacture because each kind of the die for producing products needs specialized design. In contrast, in an electromagnetic dynamic plasticating (EMDP) extruder for plastics, invented by Qu [9,10], there is a reciprocating vibration force field introduced into the whole plasticating and extrusion process, including solid transfer, melting and melt flow, resulting in positive effects on the material transportation and plasticizing. Because of the vibration of the screw, an additional stress is added to the shear flow of the polymer melt. The flow status of the polymer melt is thus altered. Rheological behavior of the materials is dependent on the stress vibration frequency and amplitude as well as temperature and pressure. As a result, the inner microstructure of the products is also changed during forming and solidifying of the extrudate, which could greatly enhance product properties [11]. For example, in extruded PP-CaCO<sub>3</sub> and LDPE-CaCO<sub>3</sub> blends [12] through EMDP, the CaCO<sub>3</sub> particles could be diffused easily in the polymer and dispersed evenly in the extrudate, hence the overall property of products would be improved. It had been verified that the EMDP had multiple advantages over traditional extruder, such as low energy consumption, high output, low melt die swell ratio, and superior mechanical and surface quality of the extruded products [12, 13]. But few investigations have been done on its effect on the relationship between microstructures and properties.

In this work, an attempt is made to enhance the HDPE properties by vibration plasticating extrusion process. We has prepared HDPE sheets using EMDP extruder, and studied vibration force field effect on the microcosmic structure and mechanical properties of the samples.

## **Experimental**

### *Material*

The material used in this work is HDPE (grade 5502) with a melt flow index of 0.4g/10min (T=190°C, P=2.16kg), supplied by Shanghai Kinfei Petrochemical Corp. China.

### *Equipment (EMDP)*

A SJDD-260 electromagnetic dynamic-plasticating (EMDP) extruder is used to prepare the HDPE sheets. The schematic drawing of this extruder is illustrated in figure 1. A single screw extruder is installed inside a specifically designed motor, and thus the whole plasticating and extrusion process of the materials is finished inside the electrical rotor. The magnetic body is rotated in a non-steady state vibration within an electromagnetic winding. The screw and rotor are coaxially connected, the screw also does circumferential and axial vibration, thus the mechanical vibration induced by

electromagnetic field is introduced into the whole plasticating and extrusion process, including solid transportation, plasticating, and extruding. This is the vibration plasticating extruding (VPE). The extruder can be also used as a traditional single-screw extruder if the screw does not do axial vibration. In this case, it is mentioned as conventional static extruding (CSE).

The die for extruding is a T shape slit die with 80 mm width and 2.0 mm thickness.

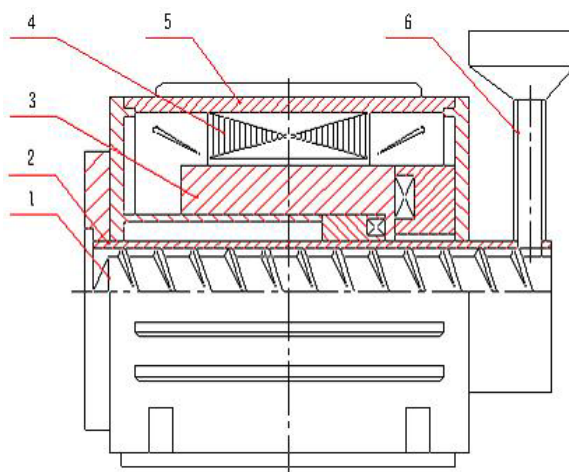

Fig. 1 The schematic drawing of the electromagnetic dynamic plasticating extruder (1 screw 2 barrel 3 rotor 4 stator 5 mount 6 hopper)

#### *Sample Preparation*

The HDPE sheets were extruded by conventional static extrusion and vibration plasticating extrusion. For both extrusion, the temperature profile used was 165, 200, 195 and 195°C from hopper to die, the screw rotation speed was maintained at 20rpm, and the sheet take-up speed was adjusted to the same as extrusion speed to avoid elongation of the extruded sheet.

For vibration extrusion, vibration frequency of the screw in the axial direction was 2-16Hz, and the amplitude was 40-200 $\mu$ m.

In each processing condition, a section of the extruded sheet was cut off for structure and property characterization after the extrusion was stabilized.

#### *Mechanical Test*

The dumbbell specimens used for tensile test were prepared along the extrusion direction (MD) and transversal direction (TD) of the extruded sheet samples, respectively. The valid geometry of the specimens is 25 $\times$ 4 $\times$ 2 mm. These tests were performed on an Instron\_Merlin series 5566 testing system at 25 °C, and the crosshead speed was 50mm/min. The average value of five samples was reported for each condition.

In Izod notched impact strength test. The specimens were obtained by machining the sheets into 70 $\times$ 10 $\times$ 2 mm bars along MD and TD, respectively. The bars were notched with a single-tooth cutter. The notch depth was 2mm. These tests were performed on

an Instron\_Merlin series POE 2000 charpy-type impact machine at 25 °C. The average value of five samples was reported for each condition.

#### *Differential scanning calorimetry (DSC)*

DSC studies were performed on a Differential scanning calorimeter NETZSCH DSC204C (Germany) in order to examine the crystal behaviors for the CSE sample and best mechanical properties VPE sample, 4-6mg specimens were cut from the extruded sheets along MD and TD separately. Aluminum pans were used. The samples were heated from 25 to 180 °C with a heating rate of 10.0 °C/min.

#### *Wide Angle X-ray Diffraction (WAXD)*

An X-ray diffractometer (BRUKER, D8 GRADDS, Germany) was used to obtain X-ray diffraction spectra. The diffraction spectra was acquired using CuK $\alpha$  radiation (40KV, 40mA), scanning at a rate of 0.02°(2 $\theta$ /s) over an angular range of 0 < 2 $\theta$  < 40°.

#### *Scanning Electron-Microscopy (SEM)*

Some impact fractured surface were selected for fractographic analysis; and some quenched fractured surface obtained at liquid nitrogen temperature were selected for morphology analysis, after preferentially etched by hot KMnO $_4$  -H $_3$ PO $_4$  -H $_2$ SO $_4$  at 60°C for 15 min, and washed with H $_2$ O $_2$  and distilled water. All the surfaces were mounted on a copper stub and coated by ion sputtering with an Au/Pd alloy prior to examination. The SEM analysis was performed on a Phillips XL30FEG scanning electron microscope (Holland).

## Result and Discussion

### *Effect of axial vibration on the Mechanical properties of extrudate*

The tensile, Young's modulus and impact testing results for conventional static and vibration plastcating extruded samples are shown in Fig. 2-5, respectively. Note that when vibration frequency  $f=0$  or vibration amplitude  $A=0$ , the data correspond to the samples obtained by the conventional static extrusion (CSE), without appended vibration on it.

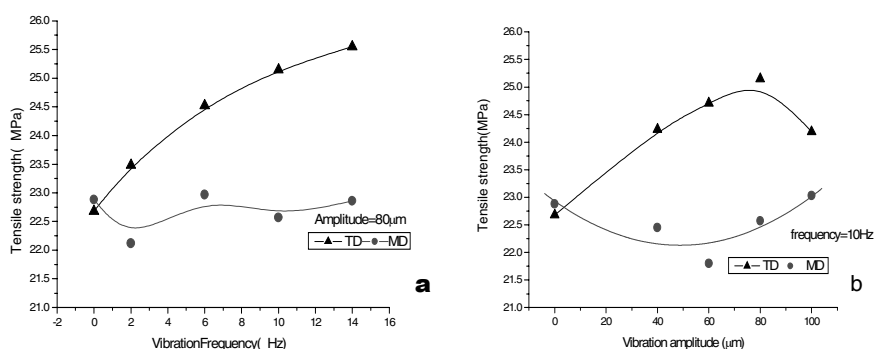

Fig. 2 Effect of reciprocating axial vibration on the tensile strength (a,  $A=80\mu\text{m}$ ; b,  $f=10\text{Hz}$ )

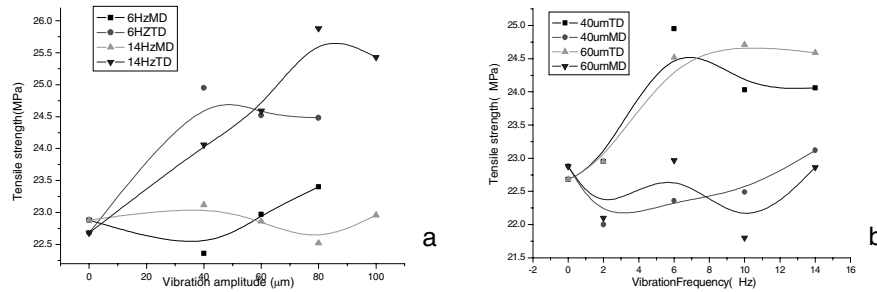

Fig. 3 The tensile strength with vibration parameter curves of HDPE sheets

### Tensile strength

From Fig. 2 and 3, it is found that the VPE process has brought out a remarkable reinforcement effect on HDPE samples in TD. The tensile strength of VPE samples steadily rises with the increase of vibration frequency. For example, at a vibration amplitude of  $80\mu\text{m}$  (Fig. 2a), the tensile strength of VPE sample in TD increases with increasing vibration frequency. When vibration frequency rises to 14Hz, the tensile strength of the sheet increases up to 25.6MPa, an increment of 13.6% than CSE sample of 22.7MPa has got. At a vibration frequency of 10Hz (Fig. 2b), the tensile strength of the samples first rises with increasing vibration amplitude, but above  $80\mu\text{m}$ , decreases. Similarity exists between the relationships of various vibration parameters and the tensile strength as shown in Fig. 3. More exactly the tensile strength of VPE sample in TD is improved by introducing the axial reciprocating vibration.

There is nearly no change on the tensile strength of extruded HDPE sample in MD direction for the VPE samples, compared to the CSE sample as shown in Fig. 2 and 3, which means the tensile strength of VPE sample in TD has been improved without lessening the tensile strength in MD direction. Besides, with vibration introduction, it is found that the VPE sample always has a higher tensile strength along TD than that along MD.

Fig. 4 shows the dependence of the corresponding Young's modulus on the vibration frequency and vibration amplitude, respectively. It is obvious that the modulus of VPE samples in TD increases as the vibration frequency or the amplitude increases. However, the modulus of VPE samples in MD decreases with the introduction of vibration, but generally maintains at a level of 520MPa after the vibration frequency rises to 6Hz. And the modulus of VPE samples in MD is lower than that in TD as well.

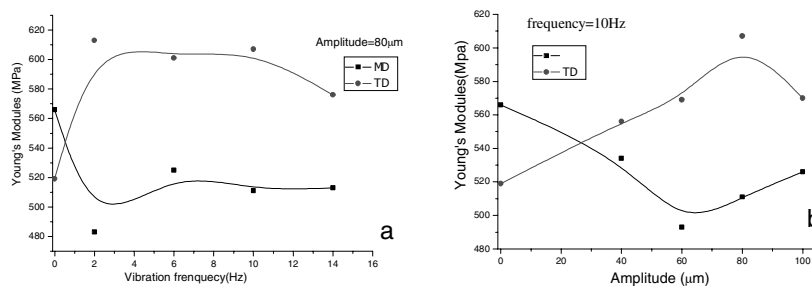

Fig. 4 The modulus – vibration parameter curves of HDPE

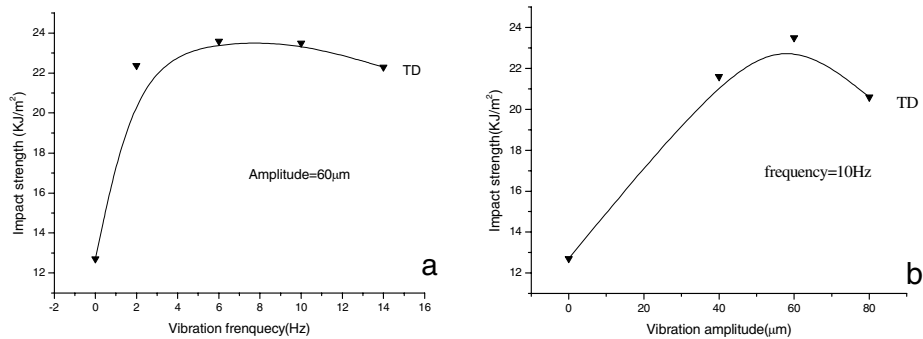

Fig. 5 The impact strength-vibration frequency curves of HDPE

### Impact property

The impact toughness along MD is listed in Table 1, and the impact strength along TD is shown in Fig 5. These data show that the vibration plasticating extruded samples have remarkable enhancement in impact toughness along both TD and MD. From Fig. 5, it is obvious that at the vibration amplitude of 60µm, the impact strength in TD increases greatly with a vibration frequency of 2Hz, and there is a little increase up to 6Hz. Then further increasing frequency does not result in higher impact strength, which keeps about 23KJ/m<sup>2</sup>, and with the increase of vibration frequency there is a decreasing trend in TD. At a given frequency of 10Hz, impact strength in TD increases with amplitude until 60µm, further increasing amplitude has no more increase but decrease too, as the vibration frequency does. With a vibration frequency of 10Hz, amplitude of 60µm, the impact strength increased from 12.7KJ/m<sup>2</sup> to 23.5KJ/m<sup>2</sup>, an 85% increase compared to CSE sample. Also, the same trend in impact strength along MD can get from Table 1. With the introduction of the vibration the impact strength along MD is improved too. At a vibration frequency of 6Hz and vibration amplitude of 100µm, the impact strength along MD show 37.8 KJ/m<sup>2</sup>, about 35% higher than that of CSE sample. However, the toughness of the VPE samples in MD is higher than that of in TD, not as the tensile strength where the TD is higher than that in MD.

Table 1. The impact strength of some HDPE samples along MD

Condition (Hz, µm)	f=0,A=0	f=2,A=100	f=6,A=100	f=10,A=80	f=14,A=60
Impact strength (KJ/mm <sup>2</sup> )	28	34.7	37.8	37	34

These results indicate that the VPE process has a considerable self-reinforcement effect on the tensile and impact properties of extruded HDPE sheets, especially along TD, and their impact toughness is improved dramatically. This effect is mainly due to the existence of stress-induced crystallization and molecular orientation [14]. During VPE processing, polymer chains are sheared both in hoop and axial direction, so the polymer chains and their segments can obtain instantaneous impulses easily from the axial vibration force. Also because of decreased chain entanglement associated with the vibration force field, the mobility of the polymer chains and their segments can be

enhanced. It is said the ability of polymer chains and their segments to move to different directions can be increased. So the polymer chains are oriented not only in flow direction but also in other directions. It is propitious to crystallization, and those molecules oriented in the direction other than flow direction can form micro crystals or serve as strong connections between lamellas. In this case, the mechanical strength of amorphous phase can be improved. As to the lower Young's modulus of VPE samples along MD and the tensile strength of VPE sample in MD than that of TD, it is mainly because of movement of the polymer chains to other directions, and the polymer chains decreased in flowing directions.

#### *Effect of axial vibration on the micro-structure of extrudate*

It is well known that mechanical properties of a material greatly depend on the microstructure and morphology. Naturally, we do DSC and WAXD analysis for the samples in TD and MD to examine their microstructure.

#### *Melting behavior and crystallinity*

Fig. 6 shows the DSC thermographs for the CSE and the VPE samples with maximum mechanical properties at vibration amplitude of 60 $\mu$ m and vibration frequency of 10Hz along MD and TD.

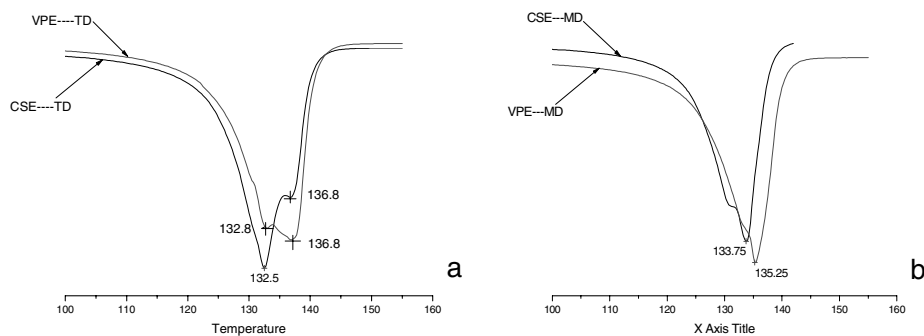

Fig. 6 DSC curves of VPE and CSE HDPE sheets (a: transverse direction; b: flowing direction)

It is obvious that the melting peak of VPE sample in MD is shifted to higher temperature, and the VPE sample in TD exhibits much higher main melting temperature than that of CSE sample, which means the more perfect crystallites exist in VPE sample. The melting peak area, or the heat of fusion, of VPE sample in MD changes from 164J/g to 175 J/g. Melting peak area obtained from the DSC is directly proportional to the degree of crystallinity, so the degree of crystallinity increases after introducing axial vibration.

However, the DSC endotherm shape in TD is different from that in MD. In the two DSC thermographs of the VPE samples in TD, it is clear that the two melting peaks differ. From Fig. 6a, it is obvious that the lower peak melting point is the main melting point in CSE sample. However the higher melting point becomes the main melting point in the VPE sample. It indicates more thermally stable structures have been formed.

To quantitatively compare the effect of the vibration on the HDPE crystallization, the DSC peak separation technique is adopted to separate the two curves in Fig. 6a. The results are shown in Fig.7 and Table 2.

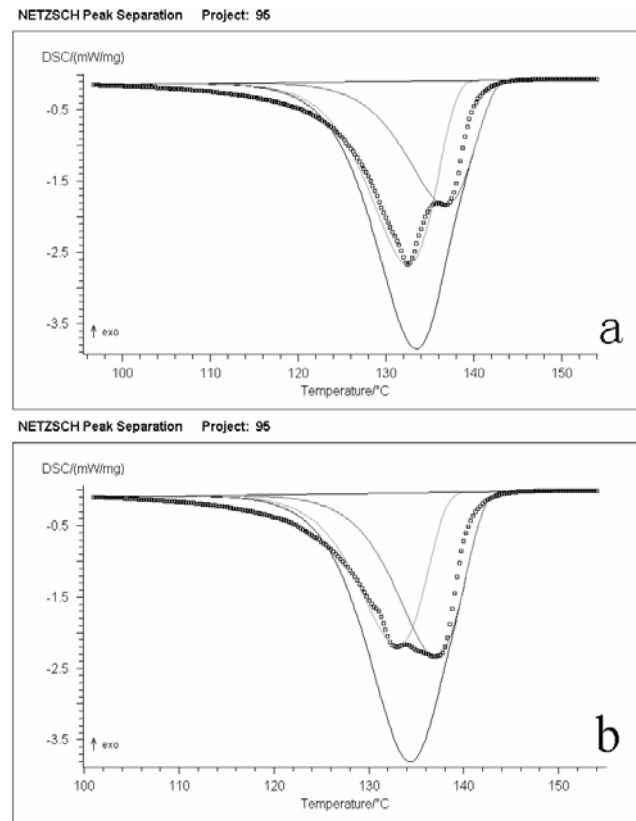

Fig. 7 The peak separation curves of the DSC in TD (a: CSE, b: VPE)

Table 2. The peak separation results of the DSC curve in TD

sample	Peak position, °C	Area, J/g	Part area, %
CSE	131.5	-105.1	57.4
	136.0	-77.9	42.6
VPE	131.4	-90.8	50.4
	136.7	-89.4	49.6

Table 2 shows that the higher peak area is improved with the introduction of vibration though the total melting peak areas change a little. This is probably an indication of a greater number of more perfect crystals which are formed under the vibration in TD, or the lamella which becomes thick during the VPE processing. The melting peak is 136.8°C for VPE sample along TD, which is higher than that (135.4°C) for VPE sample in MD. This is probably one of the possible reasons which make the tensile strength of the VPE sample in TD higher than that in MD.



The DSC results imply that the reciprocating axial vibration facilitates nucleation and growth of HDPE crystals. Because of decreased chains entanglement and obtained instantaneous impulses associated with the vibration force field, the polymer chains can nucleate at a relatively higher temperature and form more perfected crystallites [15]. On the other hand, the molecular chains of HDPE are quite flexible with few branches. It is easy for them to rearrange themselves into the crystalline lattice in the vibration field. Hence the crystallinity of HDPE is improved by the vibration force field, and the crystalline structure is more thermally stable. Vibration also increases the  $T_g$  of the amorphous regions in the interspherulities, presumably as a result of orientation of the molecules in this region [3], and the orientation of the interlamellar and interspherulitic ties which has a tremendous impact on the mechanical properties [3]. This can explain why the VPE samples have dramatic improvement in their impact strength. And it can be confirmed by the impact fractographs of the CSE and VPE samples in TD and MD as shown in Fig. 8 and 9.

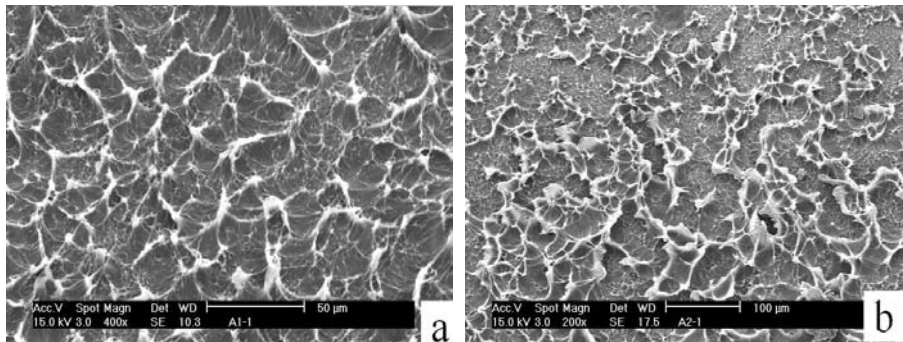

Fig. 8 The impact failure surface of CSE sample (a) in MD and (b) in TD

The SEM micrographs of the impact fractured CSE or VPE show that a ductile fracture behavior. Their difference is mainly the different deep value of the ductile socket. As shown in the fractographs of VPE sample (Fig. 9), there are many larger and deeper trips than the CSE sample (Fig. 9b) and lots micro-fibrils were pulled out during fracture, and there are longer micro-fibrils in VPE sample along MD (Fig. 9a).

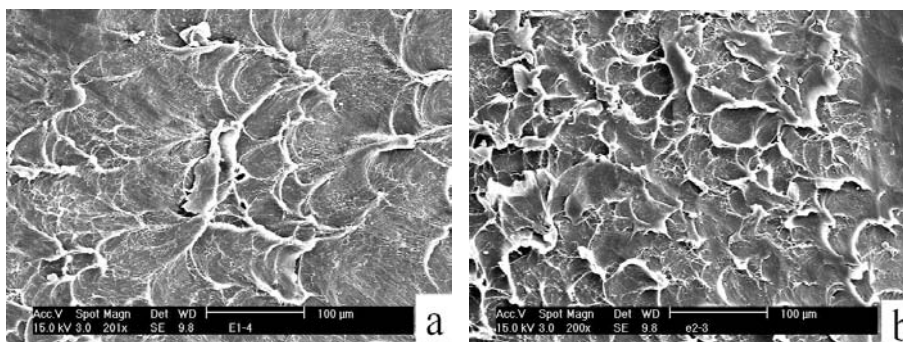

Fig. 9 The impact failure surface of VPE sample (a) in MD and (b) in TD

It indicates the strong connection of interlamellar and interspherulitic ties are formed in the VPE sample. This means the crystal structure and morphology of the extrudate have been changed by the introduction of vibration force field in the whole extrusion process.

#### *Microscopic morphology*

The morphology micrograph of CSE and VPE samples are shown in Fig. 10 and 11, respectively. The SEM micrographs of CSE and VPE sample show mainly spherulitic texture. However, VPE sample (Fig. 11) demonstrates more ordered structure, with three or four lamellas oriented in one direction (Fig. 11b), and the lamellas are thicker than that of CSE sample, which means the crystallinity of the VPE sample is improved by introducing reciprocating axial vibration. This could lead to a higher tensile strength. In Fig. 11a, it shows there are parallel lamellas formed in the VPE sample.

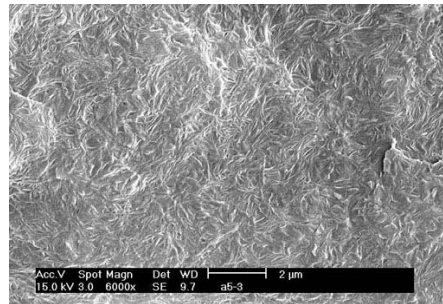

Fig. 10 SEM micrograph of the etched CSE sample

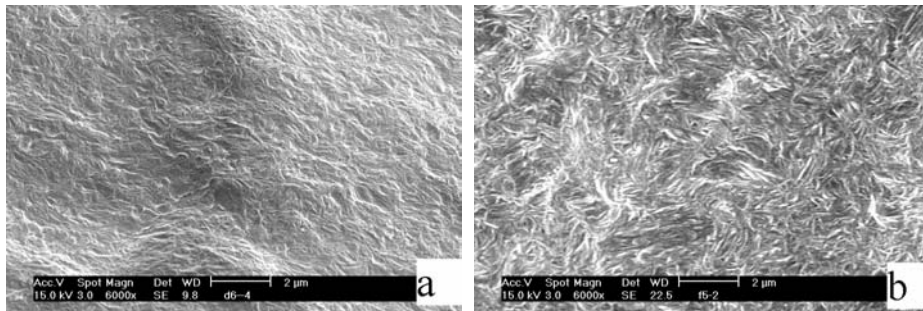

Fig. 11 SEM micrographs of the etched VPE sample (a) in MD and (b) in TD

The Wide-Angle X-ray diffraction (WAXD) curves are shown in Fig. 12 for the HDPE sheets with and without vibration in MD and TD. It is obvious that the diffraction intensity of the crystalline planes (110) and (200) of the VPE sample in MD and TD are greatly increased. This indicates that the crystalline planes of VPE sample have oriented especially in transversal direction, for the diffraction curves of VPE sample in TD is a little higher than that of in MD. This probably can explain why the tensile strength of VPE sample in TD is higher than that of in MD.

The average crystalline size calculated by the Scherrer formula [1] is listed in Table 3. The average crystal sizes (crystalline domain size) are calculated by the Scherrer formula:

$$L_{hkl} = \frac{0.9\lambda}{B \cos \theta} \quad (1)$$

where  $L_{hkl}$  is the crystalline domain size (in Å),  $\lambda$  the wavelength (1.54Å),  $B$  the full width at half maximum (FWHM – in radian) and  $\theta$  the diffraction angle(°).  $L_{hkl}$  is considered as an average crystal dimension perpendicular to the reflecting planes ( $hkl$ ).

Table 3. The average crystal sizes of the CSE and VPE sample in TD and MD

	CSE--TD	CSE--MD	VPE--TD	VPE--MD
110	184.4	186.5	210.6	199.0
200	162.0	162.0	169.5	167.3

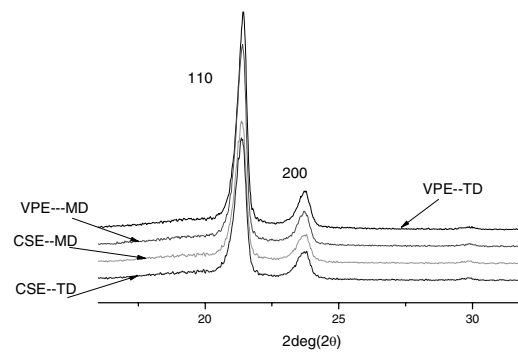

Fig. 12 WAXD profiles for extruded HDPE sheets prepared by CSE and VPE ( $f=10\text{Hz}$ ,  $A=80\mu\text{m}$ ) in MD and in TD

It is found that the crystalline sizes of crystalline planes (110) and (200) of the VPE sample calculated from the diffraction curve are bigger than that of CSE sample, and the crystalline size of VPE sample in TD is bigger than that in MD. This indicates that the crystals have got sufficient growth along transverse direction when the polymer melt cooled and crystallization, and make this direction higher tensile strength. It is in line with the tensile strength test results.

## Conclusions

VPE is an effective processing approach for the structure development control of HDPE. By introducing reciprocating axial vibration, the VPE extruded HDPE sheets exhibit higher crystallinity, higher melting temperature, larger crystal sizes and crystal structure more ordered. The reciprocating axial vibration can not only have a good effect on the texture of the spherulites formed but also have a positive effect on the interlamellar and interspherulitic ties strengthen, which can enhance the mechanical properties of the extrudate.

Mechanical property tests indicate that the reciprocating axial vibration bring out an improved overall mechanical properties of the VPE sheets. There is great improvement in tensile strength and impact toughness got along flowing and transversal directions with suitable vibration frequency and vibration amplitude, especially in transversal direction.

*Acknowledgements.* The authors would like to thank the National Nature Science Foundation (Grant No. 10472034, and 10590351) of the People's Republic of China for supporting the research presented in this paper.

### References

- [1] Fridman M.L., Peshkovskii S. L., Vinogradov G. V. (1981) *Polym Eng Sci*, 21(12):755
- [2] Isayev A. I., Wong C. M., Zeng X.(1990) *Adv. Polym Technol* 10(1): 31
- [3] Ibar,J.P. (1998) *Polym Eng Sci* 38(1):1
- [4] Zhang G., Jiang L., Shen K. Z., Guan Q.(1999) *J Appl Polym Sci* 71:799
- [5] Cao Y.R. and Li H.L. (2002) *Polym Eng Sci* 42(7):1534
- [6] Jiang L., Shen K.Z., Ji J.L. (1998) *Chemical Journal of Chinese universities* 19(4):638
- [7] Li, Z. M., Li, L. B., Shen, K.Z., Yang, M.B., and Huang, R. (2005) *Polym* 46(14): 5358
- [8] Li, Z.M., Yang, W., Huang, R., Fang, X.P., and Yang, M.B. (2004) *Macromol Mater & Eng* 289(5): 426
- [9] Qu, J. P. (1990) CN Patent, 90101034.1990-2-26
- [10] Qu, J. P. (1993) US Patent, 5,217,302.1993-6-8
- [11] Qu, J. P., He, G.J. Yu G. H., Liu G. Q (2004) *Eur. Polym J* 40(8): 1849
- [12] Qu, J. P., Xu, B.P., Jin G., He H.Z., Peng X.F. (2002) *Plast, Rub & composites* 31(10):432
- [13] Qu, J. P. (2002) *Polym- Plast Technol & Eng* 41(4):115
- [14] Li, Z. M., Qian, Z. Q., Yang, M. B., Yang W.. (2005) *Polym* 46(23): 10466
- [15] Li, Z. M., Li, L. B., Shen, K. Z., Yang, W., Huang, R., Yang, M. B. (2004) *Macromol Rapid Commun* 25(4): 553